

ProGauge ATG Console & Probes

LIQUIP

VICTORIA
THE HOME OF Fuelcraft



MAGLINK LX - Console

Advanced Tank Gauging Solutions

MagLink LX is the next generation console that offers flexible and industry standard features and functions. Using a Linux operating system and with the option of wired or wireless probes, the console can manage 1 to 32 probes. Because the MagLink LX operates using a web-based server, remote fuel management and connectivity is supported by any web-enabled PC or tablet.

Features Include:

- ▶ Colour touchscreen TFT 7" display, showing information including:
 - ▶ Product level in mm
 - ▶ Real volume & compensated at 15°C in Litres/ Gal
 - ▶ Presence of water given in mm/litres/gallons
 - ▶ Product mean temperature
 - ▶ Volume of empty portion of tank in litres/gallons (ullage)
 - ▶ Alarm signals, unit of measure
- ▶ Manages up to 32 tanks
- ▶ Web access WI-FI connection (option)
- ▶ IFSF compliance (option)
- ▶ Tank strapping table stored in NV RAM up to 500 points
- ▶ Event recording up to 32 GB with removable micro-SD card
- ▶ Safe and easy programming via web-based interface
- ▶ Integrated communication protocols including: Tokheim, Gilbarco, Wayne, Retalix, Orpak, DOMS
- ▶ Leak detection, automatic calibration and reconciliation, deliveries, trends, historical events/alarms recording

Technical Characteristics

- ▶ Intrinsically safe barrier ATEX certification
- ▶ BRA-SIP / BRA-2SIP
- ▶ CEC 10 ATEX 025 Rev. 3 (1) G [Exia] IIB
- ▶ FISCO Power Supply Um = 250 V [Exia] IIB
- ▶ Microprocessor CPU: Cortex ARM A8 @ 600Mhz
- ▶ Memory: 256 MB DDR2
- ▶ Storage: 512 MB NAND Flash
- ▶ GSM/GPRS, Radio wireless
- ▶ No. 04 low power programmable relays
- ▶ No. 06 digital/analogue inputs
- ▶ No. 1 RS232 - No. 1 RS485 serial ports
- ▶ Ports: Ethernet / USB / Can-bus
- ▶ AUX 3.5 mm jack output, to connect an external speaker

- ▶ Active or passive integrated Intrinsically safe barriers
- ▶ Synthetic resin enclosure IP40 protection
- ▶ Dimensions 265x185x85 mm

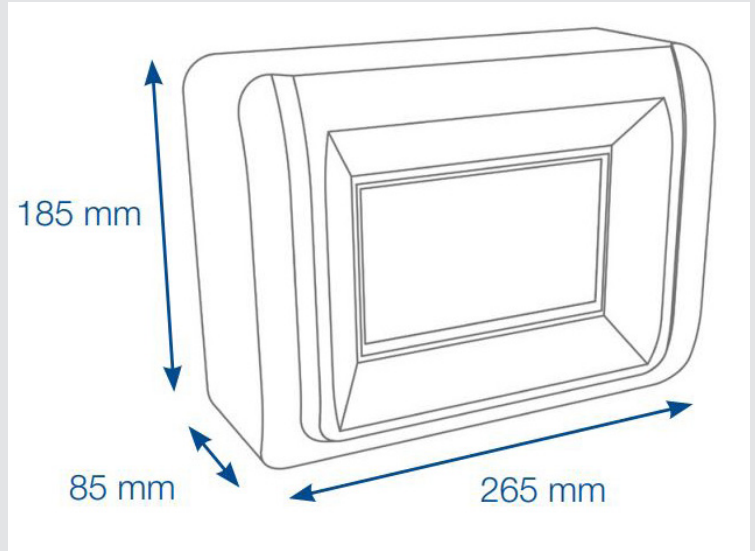

Probes - Wired and Wirelss

ProGauge Magnetostrictive Level Probes

XMT-SI-RS485

Wired Probe



XMT-SI-RF

Wireless Probe

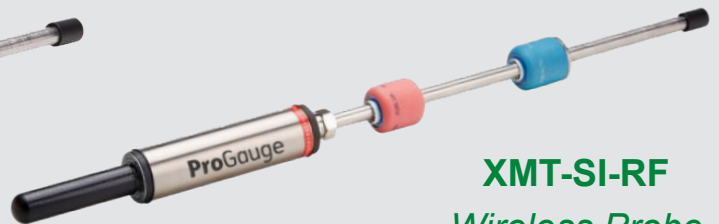

ProGauge Magnetostrictive Level probes provide continuous and highly accurate readings of liquids inside of the tank. By transmitting a high frequency electrical impulse that travels at the speed of sound, the advanced technology within the probes is able to measure the time elapsed between the initial sending of the signal and its return to the float, giving an unbeatably accurate fuel reading which is then relayed to the ProGauge console on site or directly to the Point of Sale (POS).

Wired or Wireless?

Our wired probes are ideal for sites which already have the required cabling to enable easy installation and function. Benefitting from fast and reliable data transmission, our wired probes are suitable for both above and below ground tanks and are the product of choice for many operations across the globe.

ProGauge's wireless liquid level probes are perfect for sites wishing to avoid expensive digging, wiring and cabling costs. Our wireless probes are able to transmit data up to 80 metres from underground tanks - a distance which can be extended to 800m with the aid of an additional above ground RF receiver - and are well-equipped and rigorously tested to manage environments where wireless coverage is typically limited. The ProGauge wireless liquid level probes benefit from all of the same features as the wired probe.

Standard Features:

- ▶ Magnetostrictive technology
- ▶ Supports diagnostic and maintenance functions
- ▶ Single float monitors both petroleum and diesel
- ▶ Remote configuration of operation parameters
- ▶ Riser or adjustable connection to the tank
- ▶ 500 - 5,500mm measuring range.

Calculation of data relating to:

- ▶ product level, given in measurements of 0.01mm
- ▶ water presence, given in measurements of 0.01mm
- ▶ product temperature

Measuring and resolution accuracy:

- ▶ standard measuring accuracy: +/- 0.5mm (minimum)
- ▶ standard resolution: +/- 0.01mm
- ▶ temperature accuracy range -20 +70°C: +/- 0.2°C
- ▶ temperature resolution: $\pm 0.0625^{\circ}\text{C}$

Specifications:

- ▶ Intrinsically safe
- ▶ Stainless steel enclosure \varnothing 50 mm IP68 (submersible up to 1.2 m per 24 hours)
- ▶ In 50mm (2") riser installation
- ▶ 22mm (7/8") circular connector with standard cable length 2 m (\varnothing 9 mm, hydrocarbon resistant in accordance with ENI specification)
- ▶ Power supply: 12 VDC
- ▶ No. 4 digital inputs
- ▶ RS485 serial port/antenna
- ▶ I.S. circuits to wire to an intrinsically safe barrier active (BRA-SI) or passive (BRA-SIP) (only for RS485 series)
- ▶ CEC 09 ATEX131 Rev. 4 Ex II 1G Ex ia IIB T4 Ga Ex II
- ▶ 1D Ex Ta IIIC T 135°C Da IP66/68
- ▶ FISCO Field Device Ex ta IIC T4



Wireless SI XMT-RF Probes

Intrinsically safe version battery operated

- ▶ Wireless transmission to the RF receiver up to 2 km line of sight.
- ▶ RF repeater for difficult environmental application
- ▶ Wake up on radio function
- ▶ Power up 500 mW adjustable
- ▶ RF signal measurement and display
- ▶ Calculation of data relating to:
 - ▶ Product level in 0.01 mm
 - ▶ Interface level in 0.01 of mm (water presence detection)
 - ▶ Product mean temperature up to max. 5 integrated digital sensors.
- ▶ Standard measuring accuracy: +/- 0.5 mm
- ▶ Standard resolution: +/- 0.01 mm
- ▶ Temperature accuracy range -20 +70 °C: +/- 0.2 °C
- ▶ Temperature resolution: ± 0.0625 °C

RF Receiver

For wireless probes model XMT-SI-RF.

The same device, depending on the settings, can be used also as a repeater. This is useful in those cases of critical conditions due to the distance rather than the infrastructures present.

Other probe configurations available on request.



XMT-RF Probe



RF Receiver

476 Boundary Rd
Derrimut
VICTORIA 3026

Phone: 03 9311 7822
E-mail: sales@liquipvictoria.com.au

